



WCARS.org
JUNE 2011

The Official Publication of
The Western Carolina Amateur Radio Society, Inc

President's Microphone

We have finalized the plan and **WILL** meet at the West Asheville Library on Haywood Road.

HOWEVER, due to a mixup with the calendar at the library, we will be meeting on **JUNE 9th** - one week later than usual. They had put us down on the wrong date. To make it easier for all of us, we decided to just delay the meeting one week and keep the date already on the books at the library.

Use the **ENTRANCE** next to the Police sub-station, go down the hall and I'll have the door to the room open and/or have someone in the hall to direct you to the right place.

Please come and make your presence known and check out the meeting facilities. This could be our permanent meeting place if you like what you see.

I have also scheduled meetings at the library for **JULY 21** and also for **AUGUST 4**.

MARK YOUR CALENDARS.

73,
Scott, W4IYS

**Please see PAGE FIVE
WHICH CONTAINS TWO MAPS...**

**One for the Library &
One for the Field Day Site**

(For Email it will be a **SECOND** attachment)

**Meeting for June....
W. ASHEVILLE LIBRARY
HAYWOOD ROAD - W. ASHEVILLE
7:30 PM June 9th**

Why can't I get into W4MOE repeater?

Dick Burns, K8SKX

A common problem for a number of hams is getting into the local repeaters they'd like to access. This is especially true of new hams, who have purchased a new 2m HT and are disappointed that "it" doesn't work right, that is, won't access the repeater.

So what does this have to do with Buncombe County ARES (BCARES)? If you can't get into the repeater to participate in scheduled nets you are less likely to continue with BCARES, which means losing potentially good ham volunteers to help during real radio communication emergencies.

Hand held radios typically have a very short flexible antenna commonly called a "rubber duck." A common reference for antennas is a half wave dipole. If you consider that a dipole has \emptyset (zero) db gain, the rubber duck usually has **-3 to -6 db** gain relative to the dipole (called dbd). What this means is that if we use the same power into both antennas, the rubber duck will appear to have one-half or one-fourth the power output of a dipole. In other words, your 5 watts into the rubber duck is effectively only 2.5 or 1.25 watts in comparison to a dipole. Is it any wonder that you can't access the repeater from some locations especially if you are "behind" obstructions?

A simple solution to this problem if you are working from a fixed location or "fixed portable" location is to use a better antenna. There are a number of external antennas you can easily make that will provide gain and may provide the extra signal you need to get into the repeater.

One suggestion is to make a small 3 element 2 meter beam, such as described in the accompanying article taken from the 1997 ARRL handbook. This antenna should give you 6-7 dbd gain. This translates for a 5 watt HT to the same as 20 watts into a dipole or maybe 80 watts into that rubber duck!

This homebrew beam can be constructed for a "few" dollars if you have to buy everything new, less if you have old PVC pipe lying around. It's easy to make & will probably take you more time to collect the pieces than the actual construction.

Give it a try....

73 Dick K8SKX, EC BCARES
(SEE PAGE THREE)

Minutes of Meeting May 5, 2011

Bob Dockery, WD4CNZ

The May 5, 2011 meeting of WCARS was called to order at 1927 by Scott, W4IYS, WCARS President, with an invitation to join him in the Pledge of Allegiance.

Attendees then introduced themselves with name, call-sign (if any) and QTH.

A correction to the April Minutes, printed in the May SMOKETEST, was made to show the Hamfest date is in JULY and not in June as printed.

The Treasurers Report by Steve, N4SET showed checking/savings balance of \$11,485.53.

WB5NWA became a new member of WCARS and has asked for help in erecting an antenna due to health limitations. More information will be in the next Smoketest.

Information about the next WCARS meeting location and parking facilities will be in the next issue of Smoketest.

Tommy, K4BNP reported that May 28th is the date for Meals On Wheels marathon and various checkpoints to be manned were given. The event begins at 0830, Saturday May 28. If you can help contact Tommy. Volunteers are asked/required to have their own HT/Mobile gear capable of communicating from their particular checkpoint location.

Field Day information will be in the next Smoketest. Field Day Leader Carl, N4AA advised that the respective "Band Captains" are responsible for providing their own shelter, equipment, antenna, logging (either computer or by hand), tables/chairs, etc. Field Day will be held at the Buncombe County Fireman Training Center on Erwin Hills Road adjacent to the County EOC, near Erwin High School.

A request for help/volunteers was made by Hamfest Chairman Randy, KI4VLW. Additional help will be needed for the Concessionaire Stand throughout the event.

Club members are invited to attend the Friday evening dinner for the Hamfest Vendors/Volunteers the evening before the Hamfest. Those coming are asked to bring TWO food items and join the fellowship at 6-PM, Friday July 29th.

A donation will be made to AB Tech Electronics Department after the Hamfest for their cooperation with WCARS as well as the Museum .

Tommy, K4BNP reported that nominations are now being accepted for the annual Miriam Smith, KB4C Memorial Award, presented to an outstanding Amateur Radio Operator in Areas 12, 14 & 15 for their ARES work. Nominations must be submitted in writing either by Email or USPS.

Dick, K8SKX reported BCARES would meet May 19 at the Red Cross. Contact him at <k8skx@arrl.net>.

Connie Duncan (former member of WCARS) is on FACEBOOK and would appreciate email from members. See contact information in the April & May Smoketests.

Newly licensed members of the recent class were welcomed to the meeting.

The 50-50 drawing was held....

There being no further business, the meeting was adjourned at 2015 with fellowship following with the new licensees.

FIELD DAY - JUNE 25-26 County Fireman Training Center Erwin Hills Drive - W. Asheville

Carl Smith, N4AA

There will be a "site meeting" for all interested parties on Saturday, June 11 between 9:30-10:00 at the location. It should not last more than an hour or so. Band Captains should plan to be there to "stake your claim" to a spot on the site.

Included in this issue of Smoketest will be a map showing the location. I will also have a 2M radio running on "91" in case someone needs Talk-In.

Each Band Captain will receive an email following the site meeting with details we will discuss at that meeting.

Setup for Field Day itself will begin at 9-AM on Saturday, June 25th. On the-air operation will begin at 2-PM for all stations.

We will have a covered dish dinner Saturday evening coordinated by Roger Grindstaff, KI4FPC. Please work with him and come out for the fellowship we can enjoy at this event.

(PRAY FOR SUNSHINE TOO)

As I have stated, each Band Captain is responsible for "his site" and should plan to provide everything needed to operate - shelter, radio (s), antennas, logging facilities (computer or paper logs), etc.

I am planning to have a short program on Field Day at the June Club Meeting and hopefully will be able to answer any questions you might have. If you don't know what Field Day is, or have questions, please come to the meeting and ask. I can't promise to have all the answers, but I'll do my best.

Please remember all the folks being devastated by the tornadoes in Alabama, Arkansas, Minnesota, Missouri, Oklahoma & Texas. Don't forget all those in Louisiana and Mississippi affected by the flooding in that area. Many of these folks lost everything they owned, and hundreds lost their lives too.

HR607

So, what the heck is an “HR607”

Here is some brief background ... HR607 is a bill that was introduced in the House of Representatives (thus the “HR”) and the number is just an identifying number in the House.

(The following was taken directly from the ARRL website and is quoted here only as background information.)

“On February 10, 2011, Rep. Peter King (R-NY), Chairman of the House Homeland Security Committee, introduced H.R. 607, the “Broadband for First Responders Act of 2011,” which has been referred to the House Energy and Commerce Committee (which handles telecommunications legislation). The bill addresses certain spectrum management issues including the creation and maintenance of a nationwide Public Safety broadband network.

As part of that network, the Bill provides for the allocation of the so-called “D-Block” of spectrum in the 700 MHz range for Public Safety use. HR 607 uniquely, provides for the reallocation of other spectrum for auction to commercial users, in order to offset the loss of revenue that would occur as the result of the allocation of the D-Block to Public Safety instead of commercial auction. H.R. 607 lists, among the bands to be reallocated for commercial auction within ten years of the passage of the Bill, the paired bands 420-440 MHz and 450-470 MHz.

The inclusion of most of the Amateur 70-cm spectrum as one of the replacement bands is a major problem. The 420-440 MHz band is not Public Safety spectrum and should not be included in any spectrum swap of Public Safety allocations.

While the ARRL and all Amateurs support the work of Public Safety and recognize their need for dedicated spectrum which would promote interoperability, the ARRL vigorously opposes HR 607 in its present form. HR 607 is a direct threat to our limited spectrum and the ARRL encourages all amateurs to appropriately voice their opposition to this bill.

The following comes from our North Carolina Section Manager Bill Morine, N2COP:

The Ham Radio community, both here in North Carolina and nationwide, has made great strides in educating officials about the vital role it plays in community emergencies. The unfortunate string of storms and tornadoes which plagued North Carolina, and especially hard hit Alabama and now Missouri, showed the value of Amateur Radio. We commend the Long Island, New York Hams from Rep. Peter King’s home district who met with him and got his word that Amateur Radio will be given fullest consideration, but Ham Radio is not exempted from HR607 yet. All Hams in the U.S. need to continue their letter writing campaign until we have definitive word that Amateur Radio’s 420-440 MHz spectrum has been removed from the bill. If there are still Hams who haven’t contacted their U.S. Congressional representative on this issue, please do so.

A PORTABLE 3-ELEMENT 2-M BEAM (reprint from The ARRL Handbook 1997, page 20.62)

Dick Burns, K8SKX

“In April 1993 QST, Nathan Loucks, WBØCMT, described a 2m beam shown in Fig 20.103. The boom and mast are made from ¾ inch PVC plumber’s pipe. The three pieces of PVC pipe are held together with a PVC T joint and secured by screws. Elements can be made from brass brazing rod or hobby rods. (If you can’t find a 40-inch rod for the reflector, you can solder wire extensions to obtain the full length.)

Drill holes that provide a snug fit to the elements approximately ¼ inch or so from the boom ends. Epoxy the director and reflector in place after centering them in these holes. A pair of holes spaced ¼-inch and centered 16 inches from the reflector hold the two-piece driven element. The short ends of the element halves should extend about ¼-inch through the boom. Solder the 50-ohm feed line to the driven element as shown in Fig 20.104.

Loucks used a pair of 4-inch pieces held in place by #12 or #14 jam screws (electrical connectors) to extend and adjust the driven element to allow for operations in various parts of the 2-m band. You can trim the driven element to length for operation in the desired portion of the band if you prefer.

The figures show the beam assembled for vertical polarization. You may want to turn the boom pieces 90 degrees for horizontal polarization for SSB or CW operation.”

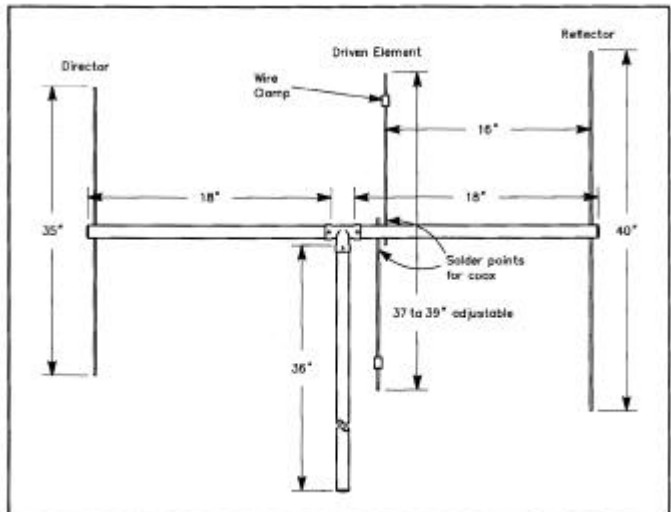

Fig 20.103—Construction diagram for the 2-m beam antenna. See text for details.

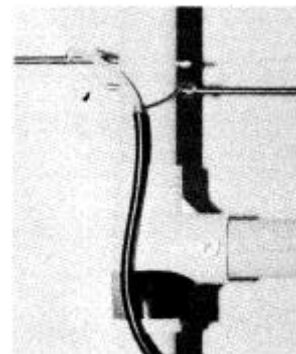

Fig 20.104—Solder the coaxial cable to the driven element pieces as shown.

SMOKETEST

Official publication of the

Western Carolina Amateur Radio Society, Inc.

PO Box 1488, Asheville, NC 28802

www.wcars.org

W 4 M O E

Repeater: 146.91 (PL-91.5)
Spivey Mountain, Asheville, NC

2011 OFFICERS

| | | | | |
|-------------------------|----------------|--------|----------|------------------------|
| President | Scott McCabe | W4IYS | 252-0583 | esmccabe@charter.net |
| Vice President | Carl Smith | N4AA | 683-4251 | n4aa@dpub.com |
| Secretary (shared) | Bob Dockery | WD4CNZ | 254-0513 | wd4cnz@charter.net |
| | Deryn Blackmon | KJ4TED | 654-9894 | derynb@charter.net |
| Treasurer | Steve Emory | N4SET | 658-0261 | n4set@arrl.net |
| Executive Committee | Randy Harris | KI4VLW | 298-6685 | rtsp71@aol.com |
| | Dean Blair | K2JB | 665-1830 | k2jb@bellsouth.net |
| Trustee - W4MOE | Norman Harrill | N4NH | 253-1192 | nharrill@bellsouth.net |
| Quartermaster | Deryn Blackmon | KJ4TED | 654-9894 | derynb@charter.net |
| Awards Chairman | Bob Dockery | WD4CNZ | 254-0513 | wd4cnz@charter.net |
| Public Information | Bob Dockery | WD4CNZ | 254-0513 | wd4cnz@charter.net |
| Hamfest Chairman - 2011 | Randy Harris | KI4VLW | 298-6685 | rtsp71@aol.com |
| Smoke Test Editor | Carl Smith | N4AA | 683-4251 | n4aa@dpub.com |

HF/VHF/UHF Net Information

| NET NAME | Freq offset / PL | Day | Local time | Notes |
|---------------------------------|-------------------|-----------|------------|-----------------------------------|
| 6600 | 145.190 + | Saturday | 9-PM | Many check-ins-Wide area coverage |
| Blue Ridge Traffic | 146.610 - | Nightly | 9-PM | ARES/Skywarn in bad weather |
| BRARC | 146.640 - 91.5 | Sunday | 9-PM | |
| Buncombe Cty Emerg. Mgt. | 146.910 - 91.5 | Wednesday | 9-PM | Directed net, ARES/RACES |
| Carolinas Net - Early | 3.573 | Daily | 7-PM | CW Traffic |
| Carolinas Net - Late | 3.573 | Daily | 10-PM | CW - 15-18 WPM Traffic |
| Carolinas Net - Slow | 3.571 | Daily | 8-PM | Slow CW - 8 to 10 WPM Traffic |
| Franklin, NC - Winesprings Bald | 147.240 + / 151.4 | Daily | 9-PM | KU4ES - Echo Link |
| Good Morning | 146.760 - | M-W-F | 9-AM | Informal, Everyone welcome |
| Haywood County Roundtable | 147.390 + 94.8 | Monday | 8-PM | Informal, Everyone welcome |
| K4UUQ Morning | 7.225 | Daily | 7-AM | Ragchew |
| Madison Cty-AmRadComTeam | 224.660 100 | Tuesday | 9-PM | Madison County Emergency Comm |
| Mount Mitchell 220 | 224.540 | Monday | 8-PM | Informal, Everyone welcome |
| Mount Mitchell Ragchew | 442.225 + 107.2 | Monday | 9-PM | Directed, Everyone welcome |
| Mount Mitchell Sunrise Net | 442.225 + 107.2 | Thursday | 9-AM | Informal - Everyone welcome |
| Mount Pisgah 220 | 224.260 | Sunday | 9-PM | Informal, Everyone welcome |
| NC Evening Traffic | 3.923 | Daily | 6:30-PM | SSB |
| NC Morning Traffic | 3.927 | Daily | 7:45-AM | SSB |
| Oasis Shrine Radio Corp. | 145.190 + | Sunday | 9-PM | |
| SATERN | 14.265 | Daily | 3-PM | Salvation Army Team-Emergency |
| Tarheel Emergency Net | 3.923 | Daily | 7:30-PM | Directed, NC Emerg. Mgt - Traffic |
| Volunteer | 147.180 + 136.5 | Friday | 9-PM | Info, News and Swap |
| WCARS Information | 146.910 - 91.5 | Monday | 9-PM | Informal, Everyone welcome |
| ??? | 224.600 | | | WB4PLA on Spivey Mtn. ??? |
| W4YK | 53.630 - 100 | Friday | 9-PM | ??? |